

MPS SERIES (PGR-6300)

Motor Protection System

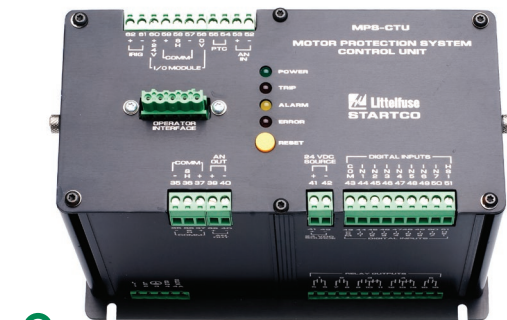
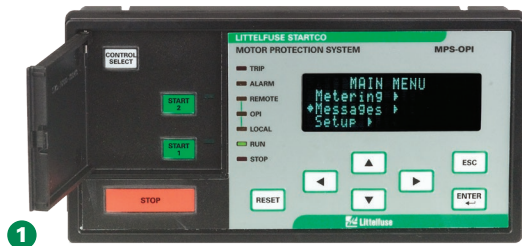

Description

The MPS Motor Protection System monitors voltage, current, and temperature to provide a comprehensive package of 22 protective functions. The MPS is a modular system with integrated protection, motor control, metering, and data-logging functions. This system is typically used to provide protection for three-phase low- and medium-voltage, medium- to high-horsepower induction motors.

1 Operator Interface (MPS-OPI)

- Large, bright, 4 x 20 vacuum-fluorescent display
- Display metered values
- Access set points
- Powered by Control Unit
- Panel mount or attach directly to Control Unit
- Remote mounting (1.2 km or 4000 ft maximum loop length)
- 1/2 DIN size
- Hazardous-location certified

2 Control Unit (MPS-CTU)

- Current inputs—5-A or 1-A secondary phase current transformers
- Voltage inputs—up to 600 V without PTs
- Earth-leakage input—5-A or 1-A secondary or sensitive transformer
- Tachometer (high-speed pulse) input
- 8 digital inputs, 5 relay outputs, 1 analog input and output
- 24-Vdc supply for OPI and RTD modules, and for digital inputs
- IRIG-B time-code input
- 1/2 DIN size, surface mount
- RS-485 network communications (Standard)
- DeviceNet™, Profibus®, or Ethernet communications available

Simplified Circuit Diagram

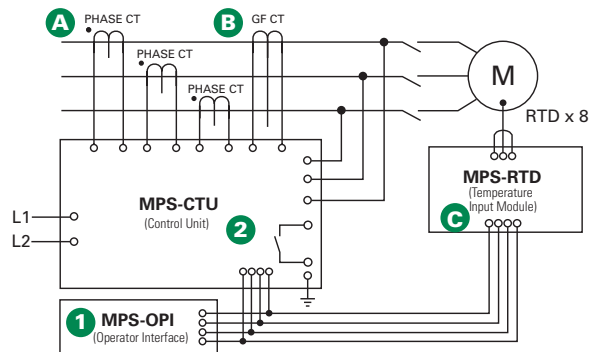

Accessories



A Phase Current Transformers

Phase CTs are required to detect phase currents.

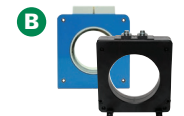

B Ground-Fault Current Transformer

Required zero-sequence current transformer detects ground-fault current. Available with 5-A and 30-A primary ratings for low-level pickup.



C MPS-RTD Temperature Input Module

Optional module provides 8 inputs to connect Pt100, Ni100, Ni120, and Cu10 RTDs.



D MPS-DIF Differential Current Module

Optional motor differential protection, compatible with core balance and summation current transformer connections.

Ordering Information

ORDERING NUMBER	COMMUNICATIONS
MPS-CTU-01-00	RS-485
MPS-CTU-02-00	RS-485 & DeviceNet™
MPS-CTU-03-00	RS-485 & Profibus®
MPS-CTU-04-00	RS-485 & EtherNet/IP™ & Modbus® TCP

ACCESSORIES	REQUIREMENT
MPS-OPI-01-00	Recommended
Phase CTs	Required
Ground-Fault CT	Recommended
MPS-RTD-01-00	Optional
MPS-DIF-01-00	Optional
SE-IP65CVR-M	Optional

MPS SERIES (PGR-6300)

Motor Protection System

Features & Benefits

FEATURES	IEEE #	BENEFITS
Overload	49, 51	Extends motor life and prevents insulation failures and fires
Current unbalance/ Phase loss/Phase reverse	46	Prevents overheating and extends motor life
Overcurrent/Jam	50, 51	Prevents catastrophic failures and fires and extends motor life
Undercurrent	37	Detects low-level or no-load conditions
Ground fault	50G/N, 51G/N	Prevents catastrophic failures and fires
RTD temperature	38, 49	Optional RTD temperature protection (MPS-RTD module) for high ambient or loss of ventilation protection
Overvoltage	59	Prevents stress to insulation
Undervoltage	27	Prevents a start attempt when it will damage the motor
Voltage unbalance	47	Detects unhealthy supply voltage
Phase differential	87	Provides sensitive protection for high-resistance winding faults
Dynamic thermal mode		Provides protection through starting, running, overload, and cooling cycles
Reduced overcurrent mode		Minimizes Arc-Flash hazards during maintenance
Starter control		Simplifies the installation by reducing component count
Metering		Displays the measured and calculated motor parameters
Data logging		On-board 64-event recorder helps with system diagnosis
Communications		Remotely view measured values, event records & reset trips
Conformal coating		Internal circuits are conformally coated to protect against corrosion and moisture

Wiring Diagram

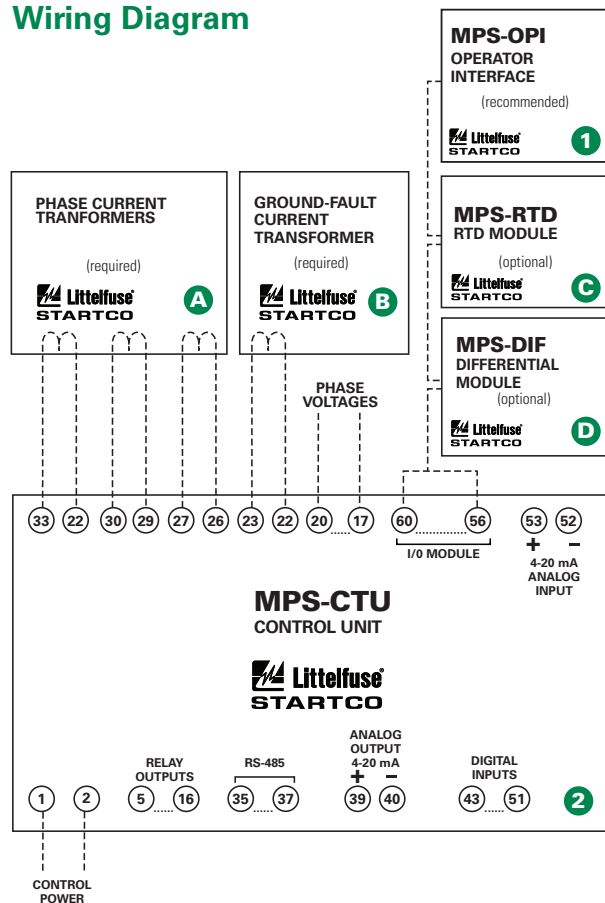

Specifications

Protective Functions (IEEE Device Numbers)	Overload (49, 51) Phase reverse (current) (46) Overfrequency (81) Overcurrent (50, 51) Jam Underfrequency (81) Ground fault (50G/N, 51G/N) Undercurrent (37) Unbalance (voltage) (47) Failure to accelerate RTD temperature (38, 49)	Unbalance (current) (46) Underspeed (14) Starts per hour (66) Phase loss (voltage) (47) Overvoltage (59) Differential (87) Phase loss (current) (46) Undervoltage (27) Phase reverse (voltage) (47) Power factor (55)
Input Voltage	65-265 Vac, 25 VA; 80-275 Vdc, 25 W	
Power-Up Time	800 ms at 120 Vac	
Ride-Through Time	100 ms minimum	
24-Vdc Source	100 mA maximum	
AC Measurements	True RMS and DFT, Peak, 16 samples/cycle, and positive and negative sequence of fundamental 50, 60 Hz or ASD	
Frequency Inputs	Phase current, Earth-leakage current, Phase voltage, 7 digital, tachometer, 1 analog	
Output Contacts	5 contacts — See Product Manual	
Approvals	CSA Certified, RCM (Australian), UL Recognized	
Communications	Allen-Bradley® DFI and Modbus® RTU (Standard); DeviceNet™, Profibus®, Ethernet (Optional)	
Conformally Coated	Standard feature	
Warranty	10 years	
Mounting (Control Unit)	Surface	
Mounting (Operator Interface)	Panel, Control-Unit mounted	

Mouser Electronics

Authorized Distributor

Click to View Pricing, Inventory, Delivery & Lifecycle Information:

[Littelfuse:](#)

[MPS-DIF-01-00](#) [MPS-TERM-04](#) [MPS-TERM-02](#) [MPS-CTU-03-00](#) [MPS-OPI-01-00](#) [MPS-TERM-01](#) [MPS-CTU-01-00](#) [MPS-TERM-03](#) [MPS-CTU-04-00](#) [MPS-OPI-MHK](#) [MPS-CTU-02-00](#) [MPS-RTD-01-00](#)